

Standard and Special Specifications Available

Specifications/Model	30JB	30JE	30JH	H30JH	30JL	H30JL	40JB	40JE	H40JH	50JA	H50JA	50JC	60JB	H60JH	90JA	H90JA	90JB	H90JB	C90J	100JB	Remarks		
Directions of Lever Operation	1-and 2-dimensional coordinate type	O	○	—	—	—	—	—	○	—	—	○	○	○	—	○	○	○	○	○	—		
		X	○	○	—	—	—	—	○	○	—	○	○	○	—	○	○	○	○	○	○	—	
		I	○	○	—	—	○	○	○	—	○	○	○	—	○	○	○	○	○	○	○	—	
		Q	○	○	—	○	—	—	○	○	—	○	○	○	○	○	○	○	○	○	○	○	
		L	—	—	—	—	—	—	—	—	○	○	○	○	—	○	○	○	○	○	○	—	
	3-dimensional coordinate type	Z	—	—	—	—	—	—	—	—	○	○	—	—	—	—	○	—	—	○	—		
		T	○	—	○	—	—	—	—	—	○	—	—	○	—	○	○	○	○	○	○	—	
		R	—	—	—	—	—	—	—	—	○	○	—	—	—	—	○	—	—	—	—	—	
		U	○	○	—	○	—	—	—	○	○	—	—	○	○	○	○	○	○	○	○	○	note 14
	Other dimensional coordinate type	S	—	—	—	—	—	—	—	○	○	○	—	—	○	○	○	○	○	○	—		
	Spring return device	○	○	○	○	○	○	○	○	○	○	○	○	○	○	○	○	○	○	○	○	○	
	Dust-proof rubber	○	○	○	○	○	○	○	○	○	○	○	○	○	○	○	○	○	○	○	○	○	note 13
	Micro-switch	—	○	○	—	○	○	—	—	—	○	○	○	○	○	○	○	○	○	○	—	Number of switch to be incorporated is depending on models.	
Digital code switch	—	—	—	—	—	—	—	○	—	—	—	—	—	—	—	—	—	—	—	—			
Alteration of potentiometer's total resistance value	○	—	○	—	○	—	○	—	—	○	—	○	—	○	—	○	—	○	—	○	Standard is 10kΩ.		
Intermediate tap of potentiometer	○	—	○	—	○	—	○	—	—	○	—	○	—	○	—	○	—	○	—	○	Standard is current tap.(with blind zone of approx. 3)		
Center position detecting switch	—	—	—	—	—	—	○	—	—	○	○	○	—	○	○	○	○	○	○	○	Available for 2-dimensional coordinate type only.		
Switch incorporated inside knob	○	○	—	—	○	—	○	○	—	○	○	○	○	○	○	○	○	○	○	○	Automatically return type.		
Rocker switch incorporated inside knob	—	—	—	—	—	—	—	—	—	—	—	—	○	○	○	○	○	○	○	—	Automatically return type.		
Sub-panel for mounting	○	○	○	○	○	○	○	○	—	○	○	○	○	○	○	○	○	○	○	○			
Potentiometer's "0" position adjusting mechanism	—	—	—	—	—	—	—	—	—	○	—	○	—	○	○	—	—	○	—	○			
Special knob shapes	○	○	○	—	○	○	○	○	—	○	○	○	○	○	○	○	○	○	○	—			
Detent mechanism	—	—	—	—	—	—	—	—	—	○	○	○	—	—	○	○	—	—	○	—	Max.7 positions available in each X and Y axis. Max.5 for H50JA.		
Specifications/Model	30JB	30JE	30JH	H30JH	30JL	H30JL	40JB	40JE	H40JH	50JA	H50JA	50JC	60JB	H60JH	90JA	H90JA	90JB	H90JB	C90J	100JB	Remarks		

○means standard specifications ○means special specifications and —means "not available". (Depending on specialty you ask, some options on the above cannot be applied.)

- (Note) 1. Life expectancy : min. 100,000 operations under the ratings at 30V.D.C./100mA. } When the switch is under non-operating condition, the condition between terminals COM and NO is "ON" and when the switch is under operating the condition, between terminal COM and NC is "ON".
2. Life expectancy : min. 200,000 operations under the ratings at 125V.A.C./5A.
3. Life expectancy : min. 100,000 operations under the ratings at 30V.D.C./100mA.
4. No. of contacts : 3 contacts per 1 circuit, Rating 100V. A.C./200mA Life expectancy:min. 50,000 operations.
5. With 1 pc. each micro-switch for X and Y axis under series connections. Rating 30V.D.C./100mA. Life expectancy: min. 100,000 operations.
6. With 1 pc each micro-switch for X and Y axis under series connections. Rating 30V.D C./100mA. Life expectancy: min. 100,000 operations.
7. Rating 125V.A.C./3A. Life expectancy : min. 25,000 operations.
8. Rating 125V.A.C./3A.Life expectancy : min. 25,000 operations.
9. Rating 12V.D.C./1mA Life expectancy : min. 1,000,000 operations.
10. Rating 250V.A.C./10A Life expectancy : min. 300,000 operations.
11. Rating 24 V.D.C./50mA Life expectancy : 1,000,000 operations.
12. We use various kinds of switch, depending on each specification of joystick controller. Thus, if you require specific applied voltage(power rating), please consult us before ordering.
13. We are using a rather stronger rubber material against environmental conditions for our dust-proof rubber cover and however, when you use it in the place where oil is adherent or lower temperature, please consult us before ordering. Please also note that, when changing the dust-proof rubber covers, some types of them can not be changed by yourselves, which means, in that case, we would kindly request you to return it to do so at our side.
14. Seesaw type potentiometer used.
15. Switch function is available. However, please note that switch function is not a real switch. Using analog output in a specific way, switch-like function is possible.
16. Please consult us for other special specifications except the above-mentioned.

Special Specifications Available

Note1: Our push button switches have 2 kinds of operating characteristic as follows.

- Momentary type: SW-ON when pushed (our standard)
- Alternate type: SW-ON after pushed, and SW-OFF when pushed once again (Available for knob type 101 and knob type 102A)

Note2: Rubber cover G-1, G-2 and G-5 are dust-proof rubbers. Please refer to page 49.





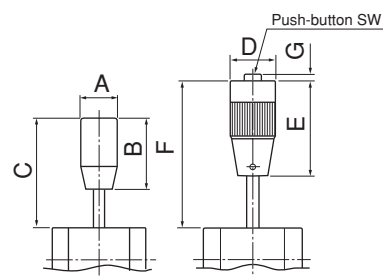



Note3: The height of C and F in the right sketch shows the dimensions when standard type of each model with YO, ZT and ZZ mounts such special knobs.

Note4: “—” in below table stands for “NOT available”.



Exterior · Shape	Type	Feature	Dimensions	30JB, JE		40JB, JE		50JA		50JC	60JB		H60JH
				Without rubber cover	With type G5 rubber cover	Without rubber cover	With type G2 rubber cover	With rubber cover	With type G1 rubber cover	With rubber cover	Without rubber cover	With type G1 rubber cover	With rubber cover
	101	Push-button knob φ 23×50L Switch incorporated inside the knob	D	—	—	φ 23	φ 23	φ 23	φ 23	—	φ 23	φ 23	—
			E	—	—	50	50	50	50	—	50	50	—
			F	—	—	Abt. 74	Abt. 74	Abt. 77	Abt. 102	—	Abt. 82	Abt. 101	—
			G	—	—	Abt. 3	Abt. 3	Abt. 3	Abt. 3	—	Abt. 3	Abt. 3	—
	102A	Push-button knob φ 30×68L Switch incorporated inside the knob with rubber cover	D	—	—	—	—	—	—	φ 30	—	—	φ 30
			E	—	—	—	—	—	—	68	—	—	68
			F	—	—	—	—	—	—	Abt. 127	—	—	Abt. 113
			G	—	—	—	—	—	—	Abt. 1	—	—	Abt. 1
	103	Push-button knob φ 16×30L Switch mounted outside the housing	D	—	—	—	—	φ 16	φ 16	—	—	—	—
			E	—	—	—	—	30	30	—	—	—	—
			F	—	—	—	—	Abt. 57	Abt. 83	—	—	—	—
			G	—	—	—	—	Abt. 3	Abt. 3	—	—	—	—
	104	Push-button knob φ 19×45L Switch incorporated inside the knob	D	φ 19	φ 19	—	—	—	—	—	—	—	—
			E	45	45	—	—	—	—	—	—	—	—
			F	Abt. 57	Abt. 67	—	—	—	—	—	—	—	—
			G	Abt. 4	Abt. 4	—	—	—	—	—	—	—	—
	201	Grip-knob φ 32×55L	A	—	—	—	—	φ 32	φ 32	φ 32	—	—	—
			B	—	—	—	—	55	55	55	—	—	—
			C	—	—	—	—	Abt. 82	Abt. 106	Abt. 132	—	—	—
	202	Grip-knob φ 20×37L	A	—	—	—	—	φ 20	φ 20	—	φ 20	φ 20	—
			B	—	—	—	—	37	37	—	37	37	—
			C	—	—	—	—	Abt. 58	Abt. 82	—	Abt. 63	Abt. 81	—
	203	Grip-knob φ 30×69L	A	—	—	—	—	—	—	φ 30	—	—	φ 30
			B	—	—	—	—	—	—	69	—	—	69
			C	—	—	—	—	—	—	Abt. 126	—	—	Abt. 114
	301	Rotary-knob φ 23×55L	A	—	—	—	—	φ 23	φ 23	—	φ 23	φ 23	—
			B	—	—	—	—	55	55	—	55	55	—
			C	—	—	—	—	Abt. 73	Abt. 107	—	Abt. 78	Abt. 106	—
	302	Rotary-knob φ 30×55L	A	—	—	—	—	φ 30	φ 30	—	φ 30	φ 30	—
			B	—	—	—	—	55	55	—	55	55	—
			C	—	—	—	—	Abt. 73	Abt. 107	—	Abt. 78	Abt. 106	—
	303	Rotary-knob φ 16×30L Fixable to type 50JA-ZZ with spring return device	A	—	—	—	—	φ 16	φ 16	—	—	—	—
			B	—	—	—	—	30	30	—	—	—	—
			C	—	—	—	—	Abt. 57	Abt. 83	—	—	—	—
	304	Rotary-knob φ 18×26L	A	φ 18	φ 18	—	—	—	—	—	—	—	—
			B	26	26	—	—	—	—	—	—	—	—
			C	Abt. 38	Abt. 48	—	—	—	—	—	—	—	—

Dust Proof Rubber (Model 30JH, 50JC, 90JA, 90JB series have a dust proof rubber cover as standard version)

For 50JA, 60JB, 60JE	For 40JB, 40JE	For 50JC	For 60JB
Type G-1	Type G-2	Type G-3	Type G-4(Flat type)
			
For 30JB, 30JE	For 30JL, H30JL	For 30JH	For 100JB
Type G-5	Type G-6	Type G-7	Type G-8
			
For 90JA, 90JB, H90JA, H90JB			
Type G-9			
	<p>(Note 1) Dust proof rubbers are mounted on the below models as standard specs. 30JH, 50JC, 60JE, 90JA, 90JB, H90JA, H90JB, 100JB</p> <p>(Note 2) We are using strong rubber materials against severe environmental conditions as our standard dust-proof rubber cover and however, in case of using in the place where oil is adherent or lower temperature, please consult us before ordering. When changing the dust proof rubber cover, it is impossible to change it on some types of joystick controller by yourselves and it requires to return us to do so. Please duly note this fact in your mind.</p>		

● **Potentiometer's "0" Position Adjusting Mechanism**

(Note) In case of with dust-proof rubber cover, the dimensions shall change and please ask us the details.

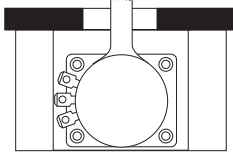
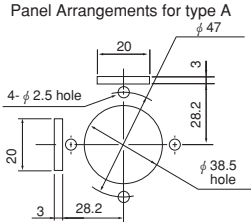
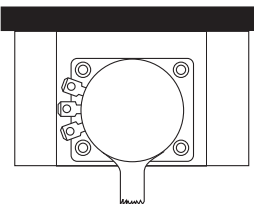
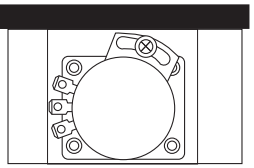
50JA	50JA, 50JC, 90JA	
Type A	Type B	Type C
<p>Operating lever exposed on panel surfaces</p>  <p>Panel Arrangements for type A</p> 	<p>Operating lever incorporated inside panel</p> 	<p>Operating lever incorporated inside panel and lockable</p> 

● **Sub-panel for mounting**

It is possible to supply each type of joystick controller with this sub-panel on request.

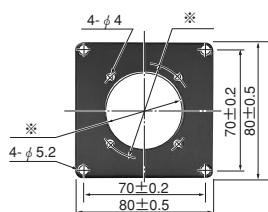

- Note : 1) Thickness of this sub-panel is 2mm.
- Note : 2) The dimensions of mark "※" are determined by the joystick controllers to be mounted.
- Note : 3) For mounting use of 90JA, L90JA, and 90JB, the outer dimension is 100×100 and inner dimension between 4-φ5.2 hole pitch is 90×90.